

# DESIGN AND DEVELOPMENT OF IGNITION POWER SUPPLY FOR ELECTRIC PROPULSION SYSTEM

SHAMNA A T<sup>1</sup>, ASNA FATHIMA K<sup>1</sup>, LISA C<sup>1</sup>, ANSAL K A<sup>1</sup>, SHIBINA K<sup>1</sup>

<sup>1</sup>*Department of ECE, Jawaharlal College Of Engineering & Technology, Palakkad, Kerala*  
[atshamna339@gmail.com](mailto:atshamna339@gmail.com)



---

**Keywords:**

Flyback Converter, High-Voltage Ignition, SMPS, Closed-Loop Control, Power Electronics.

---

---

**ABSTRACT**

Reliable high-voltage ignition is crucial for starting plasma discharge in electric propulsion thrusters. However, typical spacecraft power systems only provide low-voltage DC levels. This paper outlines the design and development of a compact ignition power supply using an isolated flyback converter. This converter can generate controlled kilovolt-range pulses from a low-voltage input. The proposed system includes high-frequency MOSFET switching, a custom step-up transformer, rectification and filtering stages, and a closed-loop digital control scheme to ensure stable and repeatable ignition performance. Protection and snubber networks help suppress voltage spikes and improve safety and reliability. Simulation studies and laboratory tests show effective voltage gain, a smaller hardware footprint, and consistent pulse regulation. These results indicate the system's suitability for laboratory propulsion testing and scalable small-satellite applications.

---



This work is licensed under a Creative Commons Attribution Non-Commercial 4.0 International License.

---

## 1. INTRODUCTION

Electric propulsion (EP) has become an important technology for modern spacecraft because it offers high specific impulse, lower propellant use, and longer mission lifetimes compared to traditional chemical propulsion. EP systems are commonly used in communication satellites, Earth-observation platforms, deep-space probes, and increasingly in small-satellite and CubeSat missions where efficiency and weight savings are vital. However, electric thrusters rely on several supporting systems for reliable operation, with the ignition power supply being crucial. The ignition unit generates a short, high-voltage pulse that ionizes the propellant and starts plasma discharge in the thruster channel. If the ignition mechanism is not stable and repeatable, starting the thruster can become uncertain, which may disrupt mission continuity and spacecraft control. A key challenge is the mismatch between the low-voltage spacecraft power supply, usually between 28 and 48 V DC, and the kilovolt-level pulses needed for ignition. Conventional high-voltage supplies often use large transformers, multi-stage voltage multipliers, or separate analog control circuits. These methods typically increase the size, weight, electromagnetic interference (EMI), and cost of the system, making them less effective for compact satellites and laboratory propulsion test setups. Additionally, poor isolation and inadequate protection against voltage spikes can endanger sensitive onboard electronics and lower overall

system reliability. As the space industry moves toward smaller, cost-effective platforms, there is a rising demand for compact, efficient, and electrically isolated ignition power modules that can deliver precise high-voltage pulses while ensuring safety and repeatability. Switched-mode power supply (SMPS) techniques offer a promising solution to these challenges. Among the various DC–DC converter designs, the flyback converter is especially suitable for low-power, high-voltage applications because of its transformer isolation, flexible voltage boost capability, and relatively few components. In a flyback setup, energy temporarily stores in the transformer's magnetic field while switching on and is transferred to the secondary circuit when switching off, allowing for significant voltage gain in a small size. When used with high-frequency switching devices, optimized transformer design, and the right rectification and filtering stages, the flyback converter can create controlled high-voltage pulses more efficiently and with a smaller footprint. Nevertheless, achieving stable ignition performance requires accurate regulation, suppression of transients, and careful management of leakage inductance, EMI, and thermal stress. This project aims to design and develop an ignition power supply for electric propulsion systems using a flyback converter setup. The goal is to convert a low-voltage DC input into controlled kilovolt-range pulses appropriate for thruster ignition, all while ensuring electrical isolation and operational safety. A closed-loop digital control strategy will regulate output amplitude and timing, improving repeatability under varying input and load conditions. Protection features, like snubber networks, clamping devices, and filtering circuits, will help reduce voltage spikes, minimize electromagnetic noise, and protect semiconductor switches. The focus will be on modular design, maintaining the integrity of transformer insulation, and selecting components that balance efficiency, compactness, and reliability. Through simulations and laboratory prototype testing, the project will assess voltage gain characteristics, pulse stability, efficiency trends, and transient behavior. The final design aims to be applicable not just to satellite propulsion systems, but also to academic and industrial propulsion test platforms that require accessible, scalable, and cost-effective high-voltage ignition solutions. By combining SMPS principles with digital feedback control and protection-oriented design, this project intends to connect traditional bulky ignition units with the increasing need for smaller, reliable, and high-performance ignition power supplies in next-generation electric propulsion applications.

## 2. ELECTRIC PROPULSION IGNITION REQUIREMENTS

Electric propulsion systems create thrust by speeding up charged particles with electric or electromagnetic fields. To do this, plasma must first be made inside the thruster chamber by ionizing the propellant gas. This ionization needs a high voltage between the electrodes to start the electrical breakdown and form plasma. The ignition power supply produces the high voltage needed to begin the plasma discharge. During ignition, a high voltage pulse is applied across the electrodes. This pulse accelerates electrons and causes them to collide with neutral gas atoms. These collisions create more charged particles, leading to plasma formation. Once plasma is formed, the main propulsion power supply keeps the discharge going and maintains the thruster's operation. An ignition power supply for spacecraft propulsion must meet several key requirements. It should generate high voltage pulses and operate reliably in the spacecraft environment. Electrical isolation from the main power system is essential to protect sensitive components and ensure safe operation. The system must also be compact, lightweight, and energy-efficient due to strict size and power limits in spacecraft applications. In the proposed design, the ignition power supply is built to generate an output voltage of about 300 V, which is enough to start plasma discharge in small electric propulsion devices. Using a flyback converter allows for efficient voltage step-up from a low input supply while keeping electrical isolation and a compact circuit design.

## 3. FLYBACK CONVERTER TOPOLOGY

The flyback converter is a DC-to-DC converter used in various power electronic systems, particularly at low and medium power levels. This converter is used in various applications where electrical isolation is a necessity, along with a high voltage step-up ability. Due to the low complexity of the circuit, along with a low number of components, the flyback converter is used in various power supplies, battery chargers, and voltage generation. For power electronics used in spacecraft, various parameters are taken into consideration, such as the compactness, efficiency, and reliability of the converter circuit. The flyback converter meets all of these requirements, as the converter includes a combination of a transformer and an inductor, which are connected in a single magnetic device. This helps the converter efficiently store the power, as well as transfer the power to the output circuit while maintaining electrical isolation. The basic configuration of a flyback converter includes:

- Input DC power source – provides the initial energy for the conversion process.
- Switching device (MOSFET) – controls the switching operation and regulates energy storage in the transformer.
- Flyback transformer – performs energy storage and voltage step-up through magnetic coupling between primary and secondary windings.
- Rectifier diode – converts the secondary AC voltage into DC output.
- Output capacitor – filters the rectified voltage and reduces output ripple.
- Load – represents the ignition circuit or discharge electrodes in the propulsion system.

The flyback converter is based on the principle of magnetic energy storage and transfer. In the switching period, the electrical energy is stored in the magnetic field of the transformer and is transferred to the output when the switch is off. By varying the switching duty ratio and the turns ratio of the transformer, the output voltage can be stepped up to a level much higher than the input voltage.

#### **A. Switch ON Mode**

During the ON state of the MOSFET switch, the input voltage is applied across the primary winding of the flyback transformer. This causes the current through the primary winding to increase linearly. This current produces a magnetic field inside the transformer core and stores energy as magnetic flux. The stored energy depends on the inductance of the primary winding and the magnitude of the current flowing through the primary winding. During the ON state of the MOSFET switch, the polarity of the transformer keeps the secondary diode reverse biased. This prevents the flow of current through the secondary circuit and the supply of energy to the output stage. Therefore, during the ON state of the MOSFET switch, the transformer is used as an energy storage component.

#### **B. Switch OFF Mode**

When the MOSFET switch is turned OFF, the current through the primary winding is suddenly stopped. This results in the collapsing of the magnetic field built up in the transformer core. Due to the principles of electromagnetic induction, the collapsing of the magnetic field induces a voltage in the primary and secondary windings of the transformer. The polarity of the secondary voltage is reversed, and as a result, the rectifier diode is forward-biased. This allows the energy stored in the transformer to flow through the rectifier diode and charge up the capacitor in the output circuit and provide power to the connected load. The capacitor in the output circuit plays a significant role in smoothing the output voltage and maintaining it at a stable DC voltage with minimal ripple. After the energy is transferred from the transformer to the output circuit, the process is repeated with the next ON period of the MOSFET switch.

## **4. DESIGN AND DEVELOPMENT OF THE PROPOSED SYSTEM**

In order to start a plasma discharge in electric propulsion systems, the suggested ignition power supply is made to transform a low voltage DC input into a high voltage output. Because of its capacity to offer high voltage gain, electrical isolation, and compact circuit design, the system is implemented using a flyback converter topology. The input power stage, flyback transformer, switching control circuit, output rectification and filtering stages, and other functional blocks make up the entire ignition power supply. In order to ensure stable high voltage generation and effective voltage conversion, each stage is essential.

### **A. Input Power Stage**

The input power stage provides the initial electrical energy required for the converter operation. In spacecraft systems, the available power is typically supplied through a regulated low voltage DC bus. This voltage is fed to the primary side of the flyback converter. To ensure reliable operation, the input stage incorporates filtering components such as capacitors and inductors to suppress electrical noise and reduce voltage ripple. These filtering components help stabilize the input voltage and prevent disturbances from propagating into the switching circuit. Additionally, input decoupling capacitors are used to supply instantaneous current during switching transitions, thereby improving the dynamic performance of the converter and protecting the power source from sudden current fluctuations.

### **B. Switching Circuit**

The switching circuit is in charge of controlling the energy transfer in the flyback converter. In this design, a power MOSFET is employed as the main switching device because of its fast switching ability, high efficiency, and low conduction losses. The MOSFET is operated by a pulse width modulation (PWM) control signal, which determines the switching frequency and duty cycle of the converter. The duty cycle directly influences the amount of energy stored in the transformer during each switching cycle and therefore regulates the output voltage level. Proper gate drive circuitry is required to ensure reliable switching operation and minimize switching losses. By carefully selecting the switching frequency and duty cycle, the converter can achieve efficient energy transfer while preventing excessive current buildup in the transformer. Furthermore, appropriate switching control helps avoid transformer core saturation and improves the overall stability of the power supply.

### **C. Flyback Transformer**

The flyback transformer is the main component in the converter and has the capability to perform the functions of energy storage and voltage transformation. The main difference between the flyback transformer and the normal transformer is that the flyback stores the energy in the magnetic core when the switch is ON and the energy is released when the switch is OFF. The main function of the transformer is to provide electrical isolation between the two circuits, which is very important in the protection of the low voltage control circuits from the high voltage output circuits. The voltage step-up capability of the converter is primarily determined by the transformer turns ratio between the secondary and primary windings. By selecting an appropriate turns ratio, the low input voltage can be converted into the required high voltage for ignition. Proper design of the flyback transformer involves selecting a suitable magnetic core material, determining the number of turns in the primary and secondary windings, and ensuring that the core does not saturate during operation. Careful design also helps reduce copper losses, leakage inductance, and core losses, thereby improving converter efficiency.

**D. Rectification and Filtering**

The secondary winding of the flyback transformer provides a high voltage pulse waveform in the switch OFF period. This AC waveform needs to be converted to a DC waveform before it can be used for ignition. A high voltage rectifier diode is used to convert the secondary output into a unidirectional current. The diode allows current to flow toward the output capacitor during energy transfer while blocking reverse current during the next switching cycle. An output capacitor is connected after the rectifier stage to smooth the pulsating voltage and provide a stable DC output. The capacitor stores electrical energy and supplies it to the load during intervals when the transformer is not delivering energy.

**5. OPERATIONAL APPROACH**

The methodology of the proposed ignition power supply system focuses on generating a high voltage output required for plasma ignition in electric propulsion devices. The system uses a flyback converter topology to step up a low input DC voltage to a high voltage level suitable for initiating discharge in the propulsion chamber. The design process involves system analysis, block diagram development, circuit design, component selection, and implementation of the converter. The overall operation of the ignition power supply is divided into several stages including power input, switching control, voltage step-up using a flyback transformer, rectification, and filtering. Each stage contributes to the efficient generation of high voltage required for ignition.

**A. System Architecture**

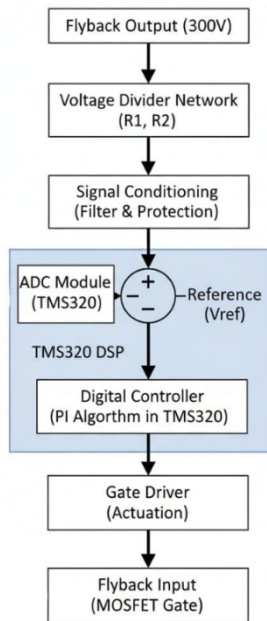

**Figure 1. Block Diagram of the Closed loop system**

The proposed system is designed using a modular architecture to ensure efficient energy conversion and reliable operation. The DC input supply provides the required electrical energy to the converter circuit. The PWM switching controller generates high-frequency switching pulses that control the MOSFET switch. The switching stage periodically stores and releases energy in the flyback transformer. The flyback transformer is the main device for stepping up the voltage and provides the necessary electrical isolation between the input and output sections. The high voltage generated in the secondary winding is then rectified using a high voltage diode and smoothed by an output capacitor. The DC voltage is then provided to the ignition electrode in the

propulsion system for the discharge of the plasma.

**B. Block Diagram Description**

The block diagram of the ignition power supply shows how the energy is transferred from the input source to the output load. The DC input voltage is connected to the flyback converter circuit through a filter, which helps in maintaining the DC voltage and reducing noise in the circuit. The controller sends a switching signal to the MOSFET gate, causing it to turn ON and allowing current flow through the transformer’s primary winding and storing energy in the transformer’s core material. Once the gate is turned OFF, the energy is transferred to the secondary winding of the transformer. The voltage is rectified using a high voltage diode and filtered using a capacitor to obtain a high voltage output. This high voltage is connected in series with the ignition electrodes of the propulsion system and helps in creating the electric field needed for ionization of the propellant gas.

**C. Circuit Design**

The design of the circuit in the ignition power supply is based on the flyback converter topology. In this topology, the primary winding is connected to the input voltage source via a MOSFET switching device. This device is controlled by a PWM signal, which defines the frequency and duty cycle of the converter. During the ON state, the current is accumulated in the primary winding, and the energy is stored in the magnetic core of the transformer. During this state, the secondary diode is reverse-biased, and no energy is transferred to the load.

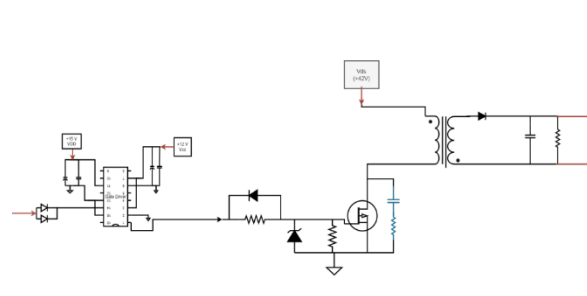

**Figure 2. Circuit Diagram Open loop System**

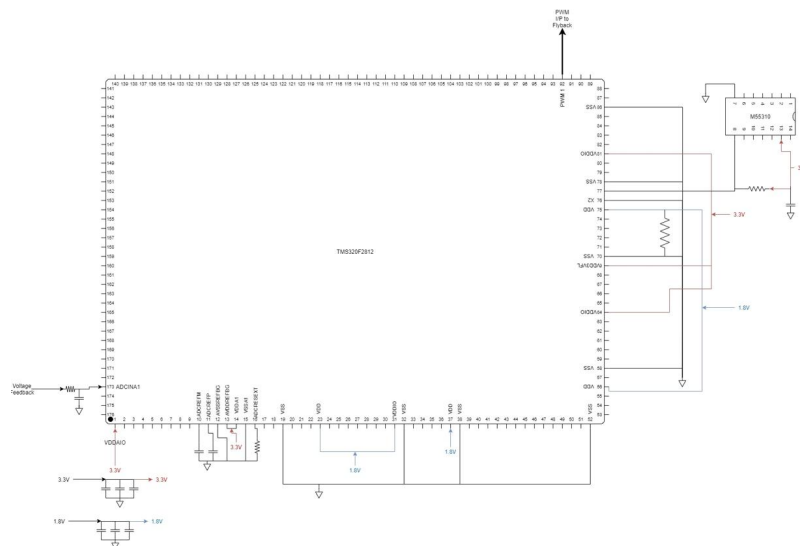

**Figure 3. Circuit Diagram of Closed loop system**

When the MOSFET goes OFF, the magnetic field collapses, and this stored energy is transferred to the secondary winding. The change in polarity in the secondary winding forward biases the diode, allowing the stored energy to be transferred to the output capacitor. The output capacitor stores this transferred

energy and provides a smooth DC voltage for the ignition system.

**D. Component Selection**

Proper component selection is critical for ensuring reliable operation of the ignition power supply. The MOSFET switch is selected based on its voltage and current ratings to withstand the switching stresses of the converter. The flyback transformer is designed with an appropriate turns ratio to achieve the required voltage step-up. High voltage diodes are used in the rectifier stage to safely handle the secondary voltage. The output capacitor is chosen with sufficient capacitance and voltage rating to reduce output ripple and maintain a stable ignition voltage. These components together ensure efficient energy conversion and stable high voltage generation for ignition.

**6. PERFORMANCE ANALYSIS**

To check the effectiveness of the proposed design of the ignition power supply, the flyback converter circuit was simulated using LTspice software. LTspice is one of the popular circuit simulation software used for the analysis of power electronics circuits. In the simulation of the flyback converter circuit, the analysis of the circuit was performed to check the effectiveness of the circuit in generating the required voltage for the ignition of the plasma used in the electric propulsion system. In the simulation circuit, the source voltage is represented by the DC voltage source. The MOSFET switch is used as the switching device in the simulation circuit. The high voltage is obtained from the flyback transformer. In the circuit, the diode is used as the rectifier. The capacitor is used as the output filter capacitor. In the circuit, the pulse signal is used as the switching signal for the MOSFET switch.

**A. LTspice Simulation Setup and Output voltage waveform**

The complete flyback converter circuit was designed and implemented in the LT spice environment. The input voltage source represents the low voltage power supply provided by the space vehicle’s power system. The MOSFET switch is connected to a pulse signal in order to create a switching period with ON and OFF intervals.

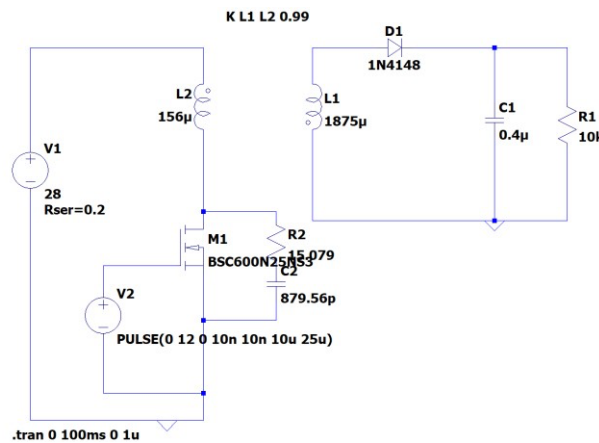

**Figure 4. Flyback converter simulation circuit**

The flyback transformer is connected with proper winding for step-up voltage as desired. A diode is connected in the secondary of the transformer for rectification of the secondary voltage. An output capacitor is connected for proper rectification and generation of a DC output voltage. The simulation parameters like switching frequency, duty cycle, and turns ratio are set with proper care for obtaining a high voltage as desired for ignition purposes.

The simulation results obtained using the LT Spice program show that the proposed flyback converter is able to convert the low input DC voltage into a high voltage output. The waveform obtained after the rectification and filtering operation shows that the converter is able to produce an output voltage of about

300 V. The waveform is due to the charging of the output capacitor as the energy is transferred from the transformer during the switching cycle. After the switching cycles, the output voltage is stabilized at the desired level required for the ignition operation. The high voltage output is required to initiate the plasma discharge in the electric propulsion systems such as ion thrusters and Hall effect thrusters.

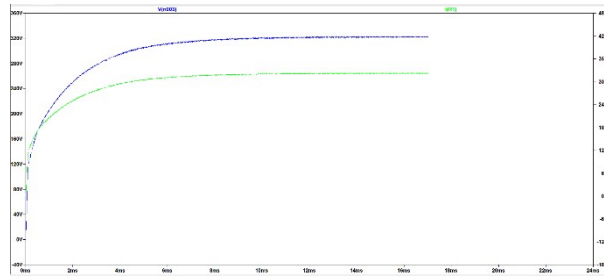

Figure 5. Output Waveform of the proposed system

### B. Bode Plot Analysis and Closed-Loop Step Response

The frequency response of the designed control system was analysed through the use of MATLAB to assess the stability of the system. The Bode plot obtained from the simulation is depicted in Figure.6. From the Bode plot, it can be determined that the system has a gain margin of 38.4 dB at  $5.55 \times 10^4$  rad/s and a phase margin of  $90.1^\circ$  at 3.34 rad/s. A high value of the gain margin indicates the ability of the system to withstand high changes in the system's gain before the system becomes unstable. In addition, the high value of the phase margin indicates the high stability of the system. It can therefore be concluded that the controller has been successfully designed to ensure a stable system with sufficient robustness to withstand parameter changes and external disturbances. From the plots, it can be determined that the system's frequency response has a smooth transition, which is a characteristic of a well-compensated control system.

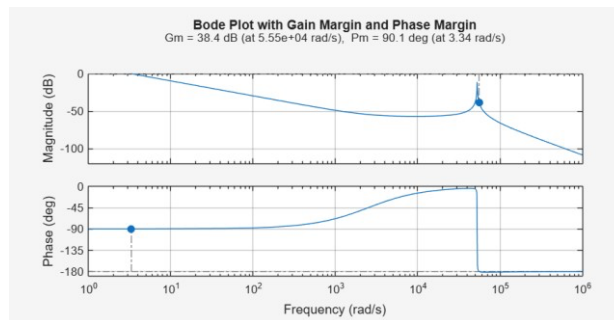

Figure 6. Bode plot of the system showing gain margin and phase margin obtained using MATLAB

A unit step input was used to assess the system's closed-loop time-domain performance with the implemented PI controller. Figure.7 displays the step response derived from the MATLAB simulation. The output amplitude of the response rises smoothly before reaching the steady-state value of 1. The system exhibits good transient behavior and little overshoot, suggesting that the PI controller was successfully tuned. Additionally, the settling behavior shows that the controller effectively lowers steady-state error while preserving system stability. The response's slow convergence to the intended output attests to the PI controller's enhancement of the system's dynamic properties and tracking performance.

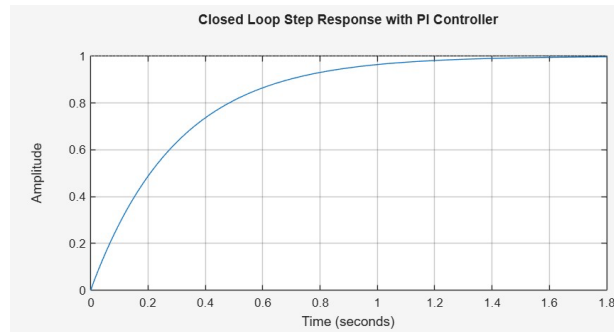

Figure 7. Step response derived from the MATLAB Simulation

## 7. CONCLUSIONS

The design and simulation of the proposed ignition power supply using the flyback converter topology were presented in this paper. The electric propulsion system requires a reliable source of high voltage to initiate the plasma discharge in the thruster chamber. The proposed system has employed the flyback converter to efficiently boost the low DC voltage level to the desired level required for the electric propulsion system. The flyback converter has been chosen due to its simple circuit configuration, high voltage gain capability, and the natural electrical isolation between the input and output stages. The proposed system has employed the MOSFET switching device, flyback transformer, rectifier diode, and the output filtering capacitor to generate the required level of high voltage output. The circuit was simulated using **LTspice**, and the results confirmed the proper operation of the converter. The simulation waveform demonstrated that the proposed system successfully generates an output voltage of approximately **300 V**, which is sufficient for initiating plasma discharge in small electric propulsion devices. The results indicate that the flyback converter based ignition power supply provides an efficient and compact solution for high voltage generation in electric propulsion applications. The design offers advantages such as reduced component count, improved efficiency, and compact implementation, making it suitable for spacecraft power electronics systems. Future work may include hardware implementation of the converter, optimization of transformer design, and implementation of closed-loop control techniques to improve voltage regulation and system stability.

## 8. REFERENCES

- [1] L. Meng, Y. Dai, S. Wang, K. Zhuang, F. Sun, and D. He, "Design and implementation of flyback converter design and control of driving power supply for unmanned robot," *IET Control Theory & Applications*, vol. 17, no. 15, pp. 2038–2046, Oct. 2023.
- [2] D. O'Reilly, G. Herdrich, F. Schäfer, C. Montag, S. P. Worden, P. Meaney, and D. F. Kavanagh, "A coaxial pulsed plasma thruster model with efficient flyback converter approaches for small satellites," *Aerospace*, vol. 10, no. 6, Art. no. 540, 2023.
- [3] C. Li, Z. Fan, and H. Luo, "High voltage transformer design based on flyback switching power supply," *Journal of Physics: Conference Series*, vol. 1449, Art. no. 012059, 2020.
- [4] D. M. Goebel and I. Katz, *Fundamentals of Electric Propulsion: Ion and Hall Thrusters*. Pasadena, CA, USA: Jet Propulsion Laboratory, California Institute of Technology, Mar. 2008
- [5] W.-M. Kim, G.-S. Lim, Y.-K. Cho, and S.-W. Lee, "Primary side regulation method for flyback converter with a peak detection circuit in CCM/DCM," *IEEE Transactions on Industrial Electronics*, early access, 2025.

- [6] S. Howimanporn and C. Bunlaksananusorn, "Performance comparison of continuous conduction mode (CCM) and discontinuous conduction mode (DCM) flyback converters," in Proc. 5th Int. Conf. Power Electronics and Drive Systems (PEDS), Singapore, 2003, pp. 1434–1438.
- [7] W.-Y. Choi, "A flyback converter with a simple passive circuit for improving power efficiency," *Energies*, vol. 17, no. 18, p. 4729, Sep. 2024.
- [8] X. Zhang, D. Zhou, and Y. Wang, "An optimized current observation and control strategy for flyback converter operating in DCM with RCD snubber," *Energies*, vol. 11, no. 12, p. 3478, 2024.